

REVISIONS			
SYMBOL	DESCRIPTION	DATE	BY
①	Added wear sleeve, relief cover, tri-lobe rotors, shims #11b & 11c. Moved drain plug. Included drw G809 under G807 and added sheet 2.	03/10/08	PO

PTO DRIVE

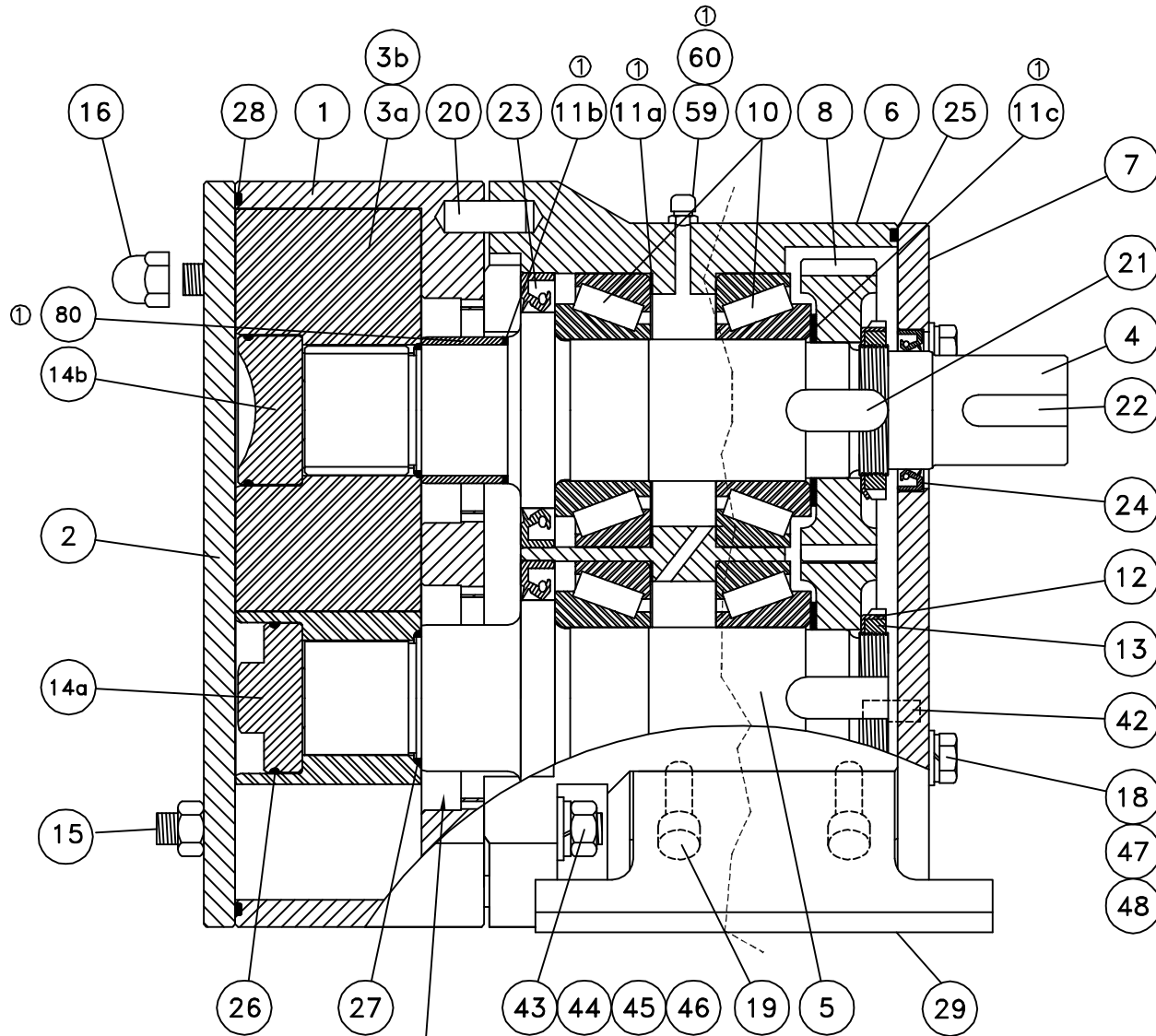

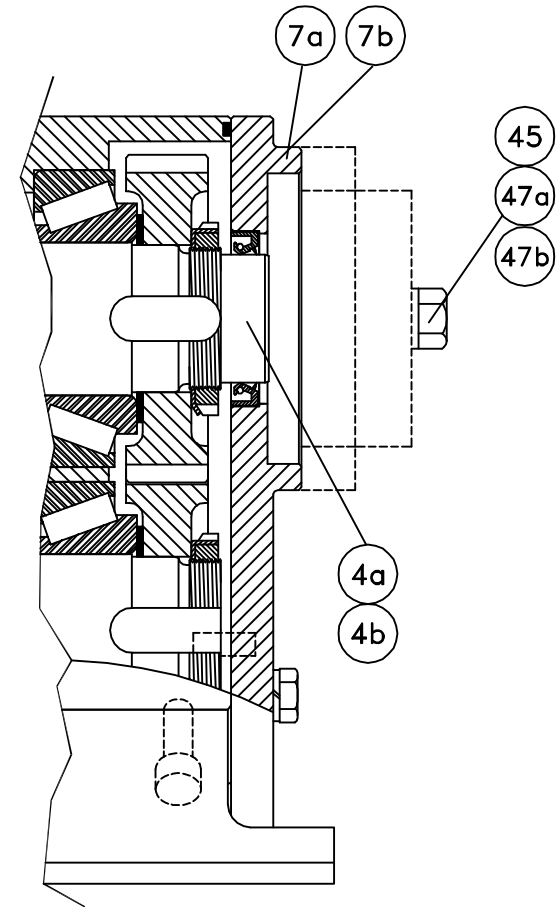

SEE DWG. G812B FOR
SHAFT SEAL PARTS

HYDRAULIC DRIVE



REGISTERED DESIGN: PATENTS PENDING

MATERIAL		BY		DATE		 FLOWTECH DIV. UNIBLOC-PUMP, INC. USA	
FINISH (UNLESS NOTED ON DWG.)		DRAWN		JPZ		DWG. TITLE	
WEIGHT		CHECKED		APP'D		UNIBLOC-PD PUMP PARTS LIST	
 		SCALE		NONE		SIZE	
		ALL DIMENSIONS IN MM				DWG. NO.	
						501,551,576	
						G807	
						RELEASE DATE MAR. 10, 2008	
						SHEET 1 OF 2	

REVISIONS			
SYMBOL	DESCRIPTION	DATE	BY
①	Added wear sleeve, relief cover, tri-lobe rotors and shims #11b & 11c. Moved drain plug. Included drw G809 under G807 and added sheet 2	03/10/08	PO

	1/8" NPTM (allen)	60	1	Oil Plug
	1/8" NPTM	59	1	Vent
4534-2	M10	48	4	Split Washer
BN622M12x45	M12x45 (hex)	47b	2	Danfoss Motor Bolt
BN622M12x40	M12x40 (hex)	47a	2	Charlynn Motor Bolt
BN670M10	M10	47	4	Washer
BN666M12X45	M12x45	46	4	Gearbox Stud
4535-2	M12	45	6	Split Washer
BN670M12	M12	44	4	Washer
4431-2	M12	43	4(8)	Hex Nut
4605	M8x22	42	2	Dowel Pin
3817		29	2	Foot
4235	226x3mm	28	1	Cover o-ring
4233	1.799"x0.103" #133	27	2	Rotor-shaft o-ring
4232	2.112"x0.103" #138	26	2	Rotor-Bolt o-ring
4239-N	7.9984"x0.139" #266	25	1	Gearbox Cover o-ring
4130	45x62x10mm	24	1	Rear Oil Seal
4135	75x105x13mm	23	2	Front Oil Seal
4716	12x8x40mm	22	1	Drive Shaft Key
4717	16x10x18mm (sq. key)	21	2	Key
4615	M12x34	20	2	Dowel Pin
BN610M10X30	M10x30 (Socket)	19	4	Foot Bolt
BN622M10X30	M10x30 (Hex)	18	4	Cover Bolt
4430-2	M12	16	4	Dome Nut
BN666M12X30	M12x30	15	4	Front Cover Stud
3381-1L		14b	2	Rotor Bolt (Slotted)
3380-1L		14a	2	Rotor Bolt (Hex)
4432		13	2	Slotted Nut
4515		12	2	Tab Washer
		11c	2	Gear Alignment shim
		11b	2	Sleeve shim ring
3671		11a	2	Shim ring
3765		10	4	Front & Rear Bearing
3617		8	2	Gears
3584	Cover For Danfoss Drive	7b		Bearing Housing cover
3583	Cover For Charlynn Drive	7a		Bearing Housing cover
3585	Cover For PTO Drive	7	1	Bearing Housing cover
3532		6	1	Bearing Housing
3239B	Relief cover, 2 way	2	1	Rotor Housing cover
3237	Relief cover, 1 way	2	1	Rotor Housing cover
3236	Plain cover	2	1	Rotor Housing cover
PART NO.	DETAILED DESCRIPTION	NO.	PCS.	DESCRIPTION
PUMP SIZE 501, 551, 576				

3702B-1L	For Wear Sleeve	5	1	Lay Shaft
3699B-1L	PTO Drive (Wear Sleeve)	4	1	Drive Shaft
	Charlynn Drive(Wear Sleeve)	4a	1	Drive Shaft
3701B-1L	Danfoss Drive (Wear Sleeve)	4b	1	Drive Shaft
3332-1L	Class E Bi-Lobe Rotor	3a	2	SS Rotor
8412-1L	Class E Tri-Lobe Rotor	3b	2	SS Rotor
3164-1	2.5" Tri-Clamp Conn. ***	1	1	Rotor Housing
PART NO.	DETAILED DESCRIPTION	NO.	PCS.	DESCRIPTION
PUMP SIZE 501				

3698B-1L	For Wear Sleeve	5	1	Lay Shaft
3695B-1L	PTO Drive (Wear Sleeve)	4	1	Drive Shaft
3696B-1L	Charlynn Drive(Wear Sleeve)	4a	1	Drive Shaft
3697B-1L	Danfoss Drive (Wear Sleeve)	4b	1	Drive Shaft
3335-1L	Class E Bi-Lobe Rotor	3a	2	SS Rotor
8442-1L	Class E Tri-Lobe Rotor	3b	2	SS Rotor
3168-1	3" Tri-Clamp Conn. ***	1	1	Rotor Housing
PART NO.	DETAILED DESCRIPTION	NO.	PCS.	DESCRIPTION
PUMP SIZE 551				

Connections Also Available in:
- ACME
- DIN 100
- DIN 80
- RST
- SMS
- NPTM
- CAMLOC

3706B-1L	For Wear Sleeve	5	4	Lay Shaft
3703B-1L	PTO Drive (Wear Sleeve)	4	1	Drive Shaft
3704B-1L	Charlynn Drive(Wear Sleeve)	4a	1	Drive Shaft
3705B-1L	Danfoss Drive (Wear Sleeve)	4b	1	Drive Shaft
3338-1L	Class E Bi-Lobe Rotor	3a	2	SS Rotor
8472-1L	Class E Tri-Lobe Rotor	3b	2	SS Rotor
3178-1	3" Tri-Clamp Conn. ***	1	1	Rotor Housing
PART NO.	DETAILED DESCRIPTION	NO.	PCS.	DESCRIPTION
PUMP SIZE 576				

Also Available in 4"

REGISTERED DESIGN: PATENTS PENDING

THIS DRAWING AND ALL IDEAS INCORPORATED IN ITS DESIGN IS THE EXCLUSIVE PROPERTY OF FLOWTECH, INC. ITS ACCEPTANCE CONSTITUTES AN AGREEMENT THAT IT SHALL BE TREATED AS A CONFIDENTIAL DOCUMENT USED FOR NO OTHER PURPOSE THAN TO AID IN ITS CONSTRUCTION, THAT IT IS TO BE RETURNED UPON REQUEST, AND THAT IT IS NOT TO BE DISCLOSED OR COPIED EXCEPT AS AUTHORIZED IN WRITING BY FLOWTECH, Inc.

FLOWTECH DIV.

UNIBLOC-PUMP, INC. USA

MATERIAL	BY	DATE	DWG. TITLE
FINISH (UNLESS NOTED ON DWG.)	DRAWN	JPZ	UNIBLOC-PD PUMP PARTS LIST
WEIGHT	CHECKED		SIZE
	APP'D		501,551,576
	SCALE	NONE	DWG. NO.
			G807
			RELEASE DATE MAR. 10, 2008
			SHEET 2 OF 2